

GoFreshDate

PREP & RETAIL FOOD LABELING SYSTEM

Powered By AD Ops

Standalone Quick Reference Guide

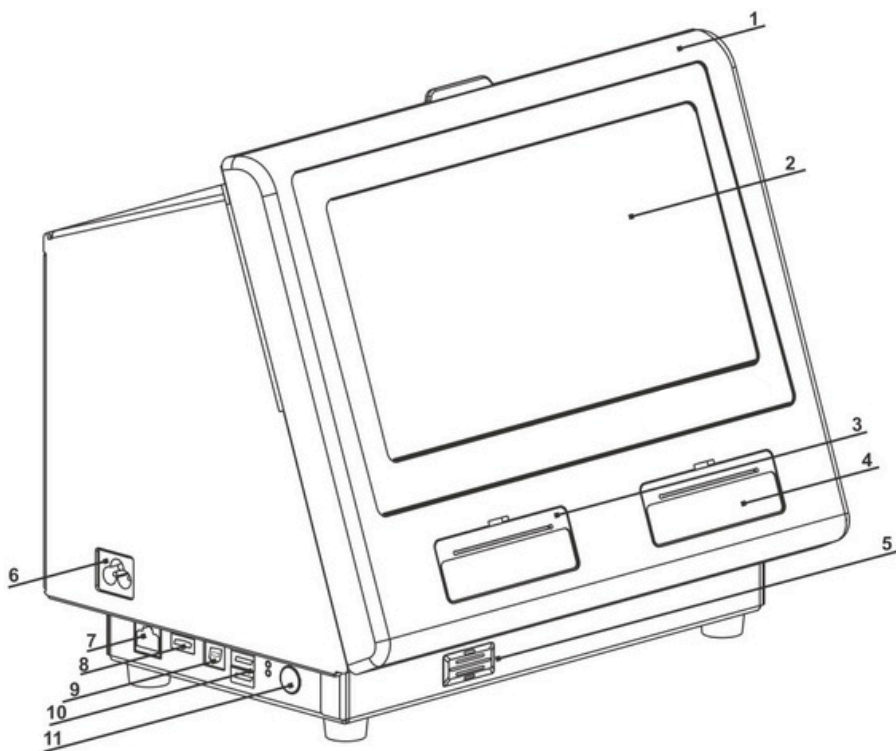

1.	Cover	5.	Speaker	9.	USB (Type B)
2.	Display	6.	Power Cord	10.	USB (Type A)
3.	Left Printer	7.	Ethernet	11.	Power Button
4.	Right Printer	8.	HDMI		

Table of Contents

Pg.1	—————	Loading Labels – Left Printer
Pg.3	—————	Loading Labels – Right Printer
Pg.4	—————	Printing Labels
Pg.5	—————	Connecting to Wi-Fi

Loading Labels – Left Printer

1. Turn on the printer then open the cover.
2. Pull on the supply tab.

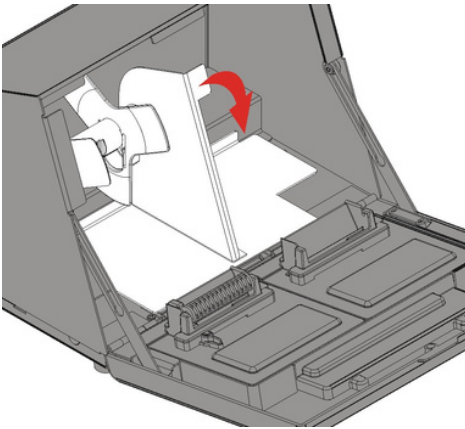

3. Unlock the supply guide and remove it.

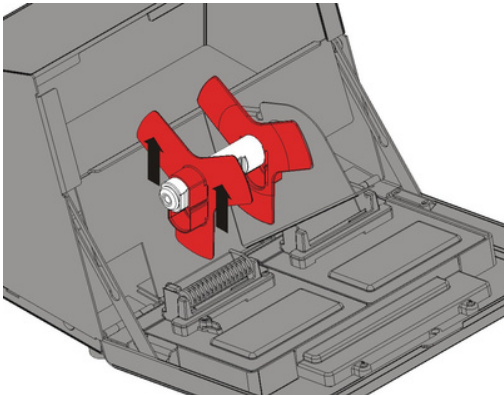

4. Place a roll of labels (label side up) on the supply holder. Place the supply guide on the supply holder.

5. Lock the supply guide.

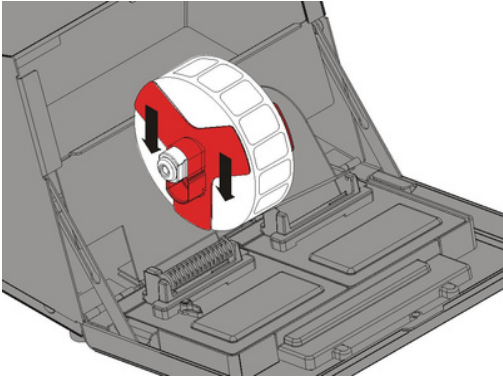

6. Put the supply tab back.
7. Guide the labels along the inside edge and into the slot.
The printer feeds the supply.

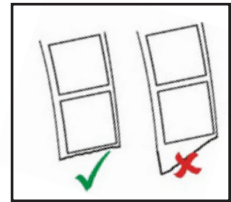
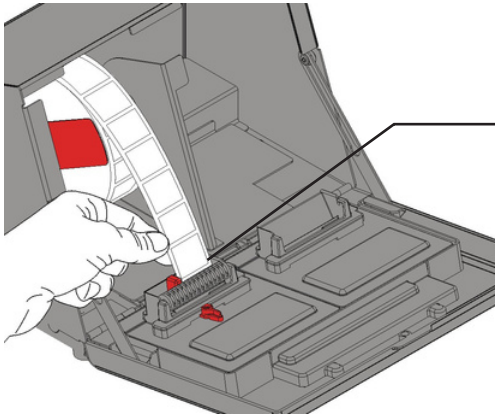

8. Slide the supply lever next to the supply. Close the supply lever.

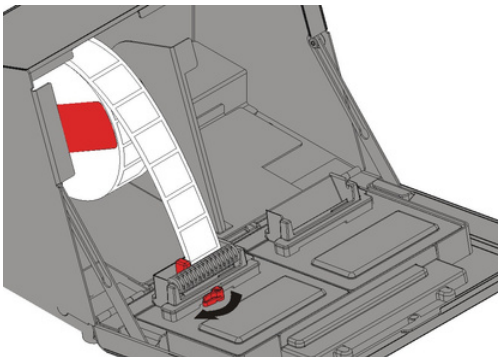

9. Close the cover.

Loading Labels – Right Printer

1. Turn on the printer then open the cover.
2. Pull on the supply tab.
3. Unlock the outer supply guide and remove it.

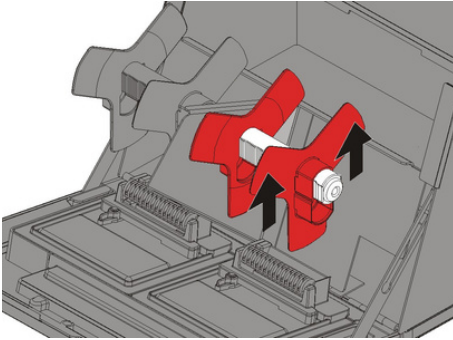

4. Place a roll of labels (label side up) on the supply holder.
5. Replace the outer supply guide and lock it in place.

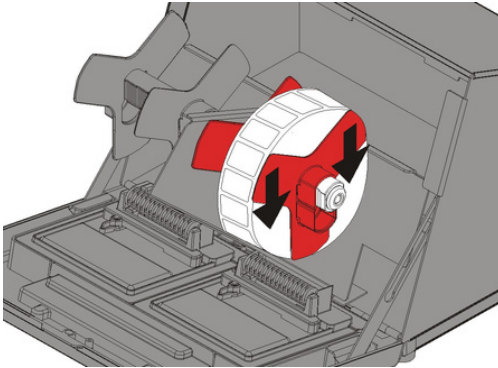

6. Unlock the inner supply guide, move it until it touches the supply, lock it into place.

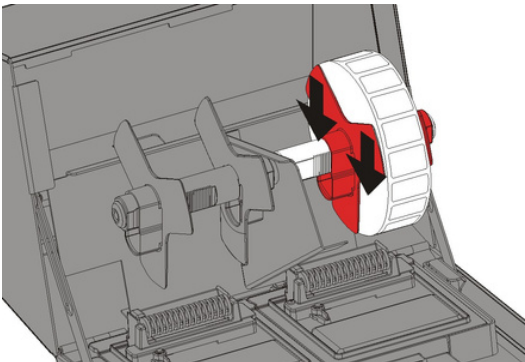

6. Unlock the inner supply guide, move it until it touches the supply, lock it into place.

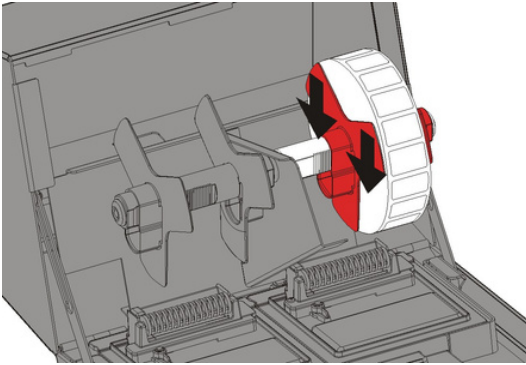

7. Put the supply tab back.
8. Guide the labels along the outside edge and into the slot. The printer feeds the supply.
9. Slide the supply lever next to the supply and close it.

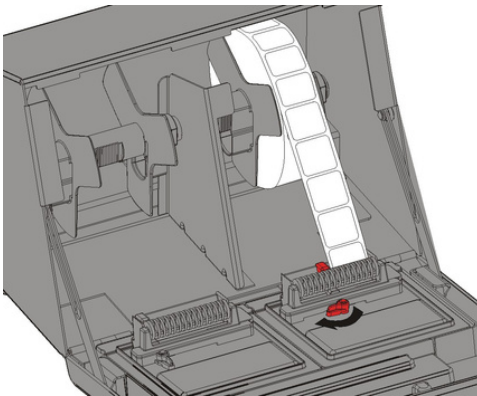

10. Close the cover.

Printing Labels

1. Turn on the printer.
2. Log in.
3. Press the product button of the label to print.
4. Select the number of labels and press **Enter**. To print one label, press **Enter**.
5. Labels print for the selected product.



Connecting Printer to Wi-Fi

1. Click on the USER ICON.

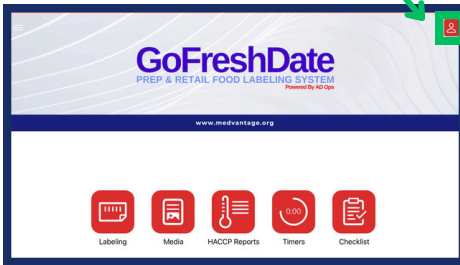

2. Click on your **USERNAME** and **SIGN IN**.
-

3. Click on the MENU icon and click **SETTINGS**.

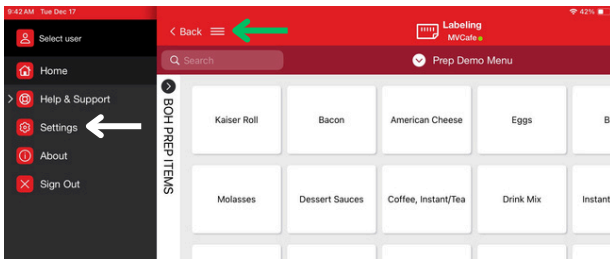

4. In **GENERAL**, click on **EXIT AD Ops**

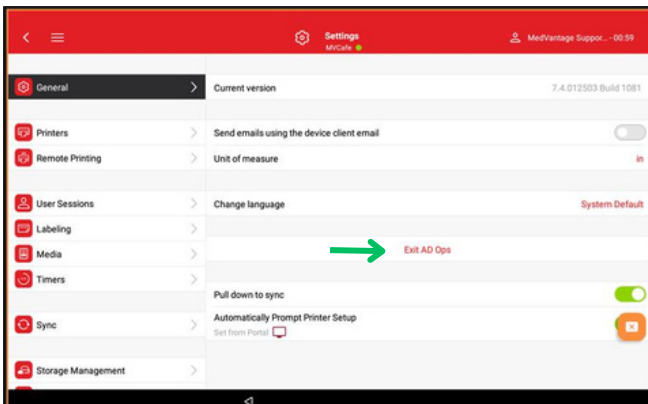

5. Click on the **CIRCLE ICON**.

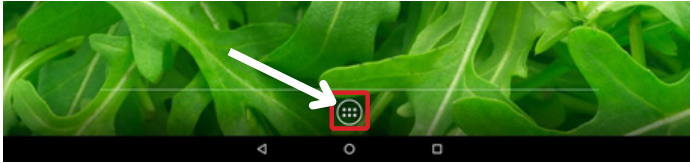

Located at the bottom of the screen

6. Click on **SETTINGS**.

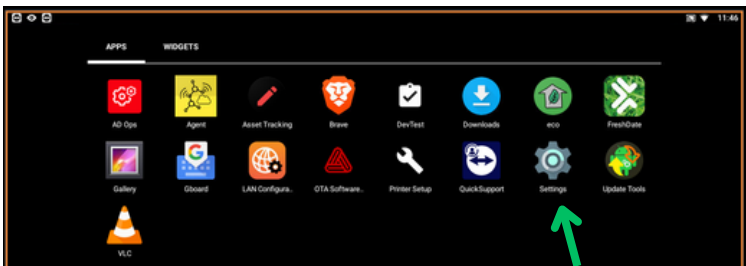

7. Click on **WI-FI**.

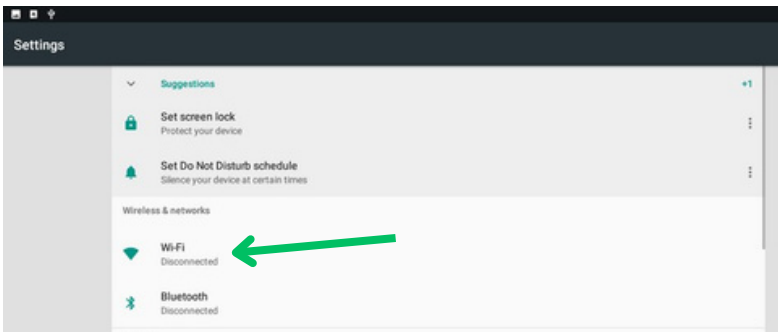

8. Connect to your **WI-FI NETWORK**. Click on the **CIRCLE ICON** to return to the main screen and re-open **GOFD**.



